

HYA005H (3P)

HYA006H (4P)

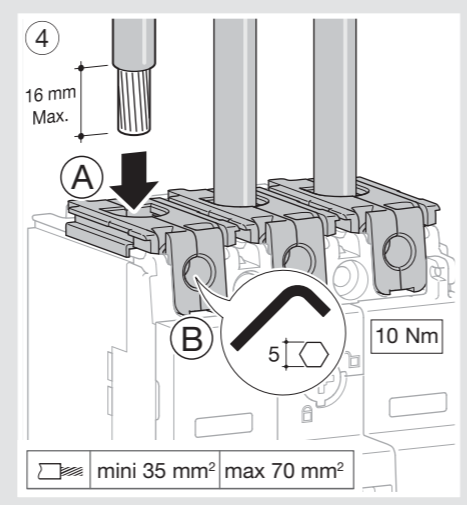

- Bornes à cages Al
- Assembling collar Al
- Anschlussklemmen Al
- Morsetti a gabbia Al
- Bornes para cables de Al
- Al-kooiklemmen
- Bornes de mordente -Al
- Tilkoblingsklemmer Al
- Ακροδέκτες για καλώδια Al
- Zaciski klatkowe Al
- Сборочный хомут Al
- محطات أفصاص Al

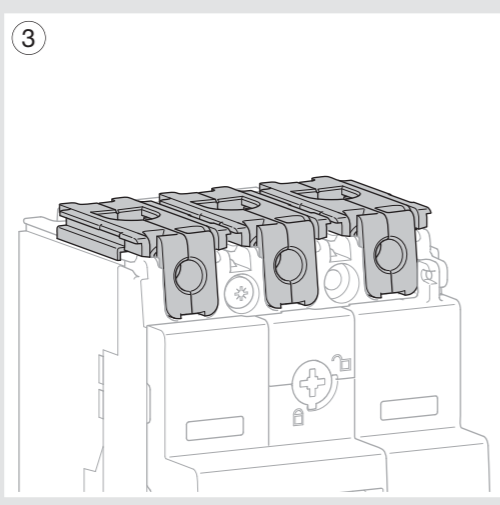
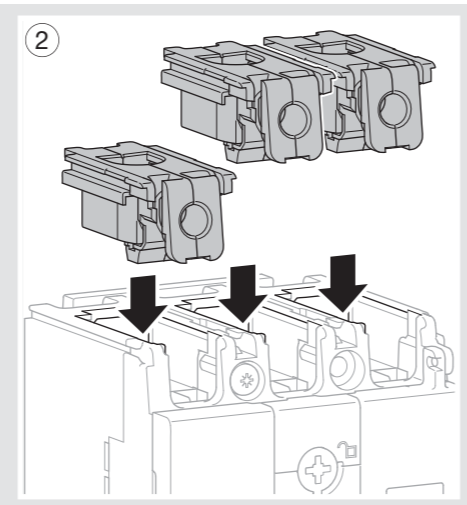
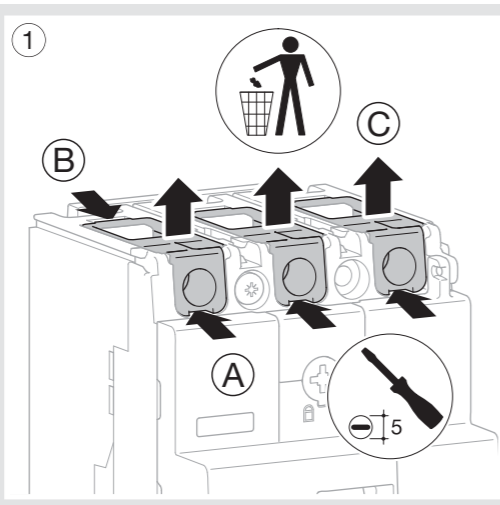

:hager

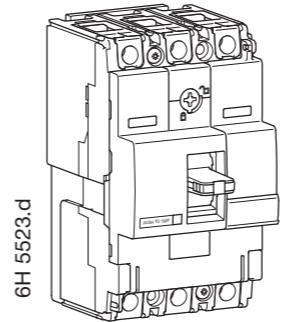

x160



- (FR) Disjoncteurs boîtiers moulés 16 à 160 A
- (GB) Moulded case circuit breakers 16 - 160 A
- (DE) Leistungsschalter 16 - 160 A
- (IT) int. scatola 16 - 160 A
- (ES) Interruptores automáticos 16 a 160 A
- (NL) Instructões de instalação
- (PT) Disjuntores gerais 16 a 160 A
- (NO) Effektbryter 16 - 160 A
- (GR) Αυτόματοι διακόπτες ισχύος 16 - 160 A
- (PL) Wyłączniki kompaktowe 16 - 160 A
- (RU) Автоматические выключатели в литых корпусах 16 - 160A
- (AR) مصبوب تغطية 16 إلى 160A

- Notice d'instructions
- User instructions
- Montageanleitung
- Istruzioni di montaggio
- Instrucciones de uso
- Gebruiksaanwijzing
- Instruções de instalação
- Bruksanvisning
- Οδηγίες Χρήσης
- Instrukcja obsługi
- Руководство по эксплуатации
- دليل الاستعمال

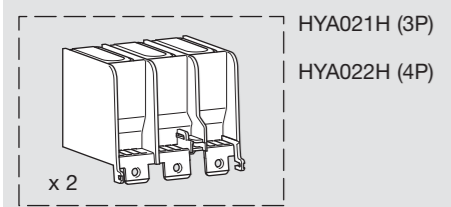
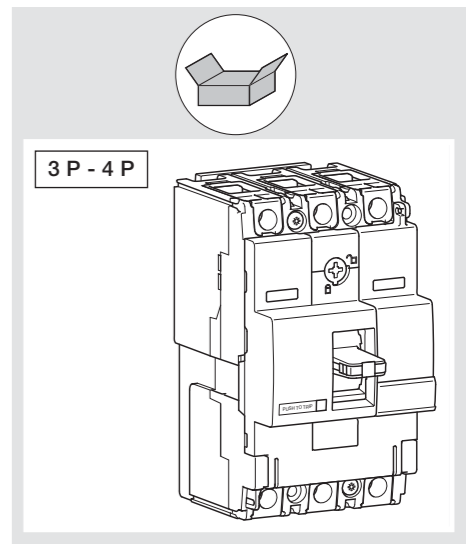
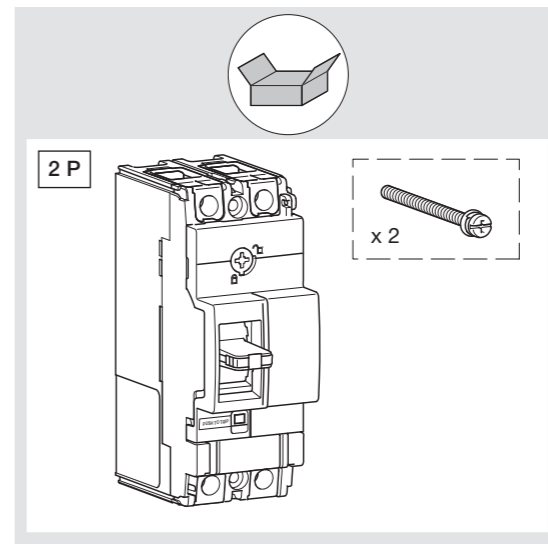
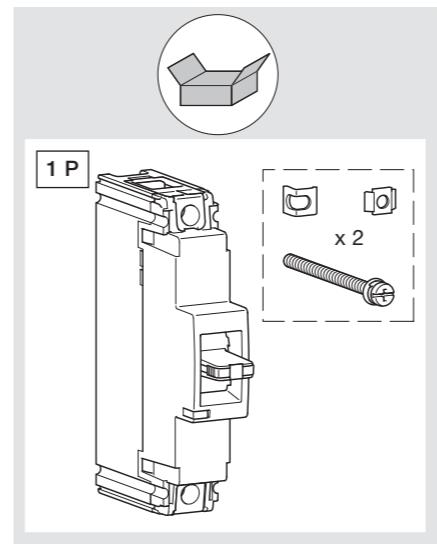

HYA021H (3P)

HYA022H (4P)

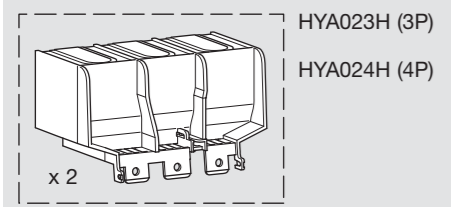

HYA023H (3P)

HYA024H (4P)

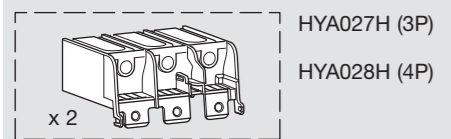

HYA027H (3P)

HYA028H (4P)

- Capot cache-bornes
- Terminal covers
- Klemmenabdeckung
- Calotte di protezione morsetti
- Tapa de bornes
- Afdekkap voor klembeschermers
- Cobre bornes
- Klemmedeksler
- Κάλυμμα επαφών
- Osłony zacisków
- Изолирующие крышки
- ذاكرة التخزين المؤقت للمحطات الطرفية

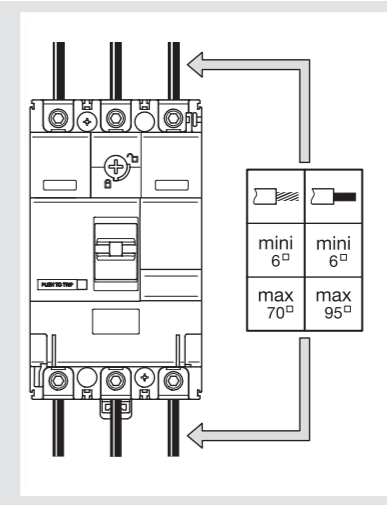
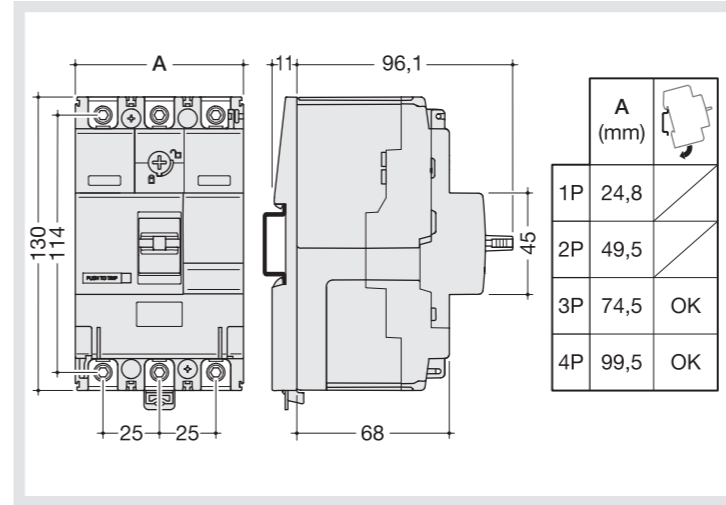
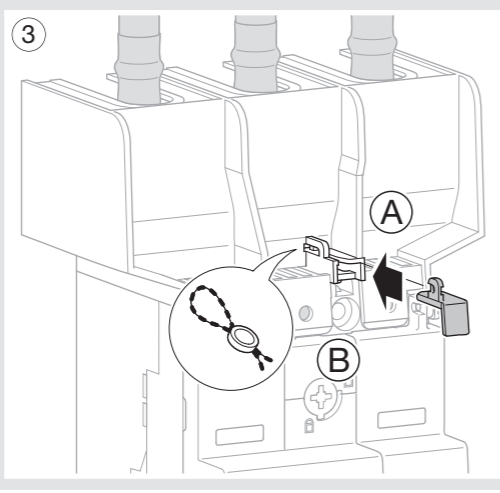
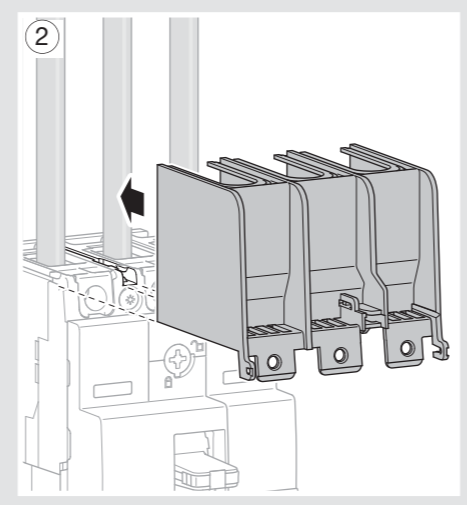
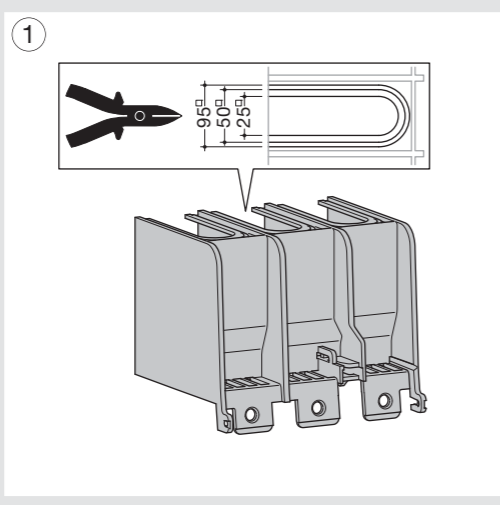

	220/240 V AC	380/415 V AC
HDA	Icu 25 kA	Ics 18 kA
HHA	Icu 35 kA	Ics 25 kA
HNA	Icu 85 kA	Ics 40 kA
HCA	Icm 2,8 kA	Icw 2 kA - 1s

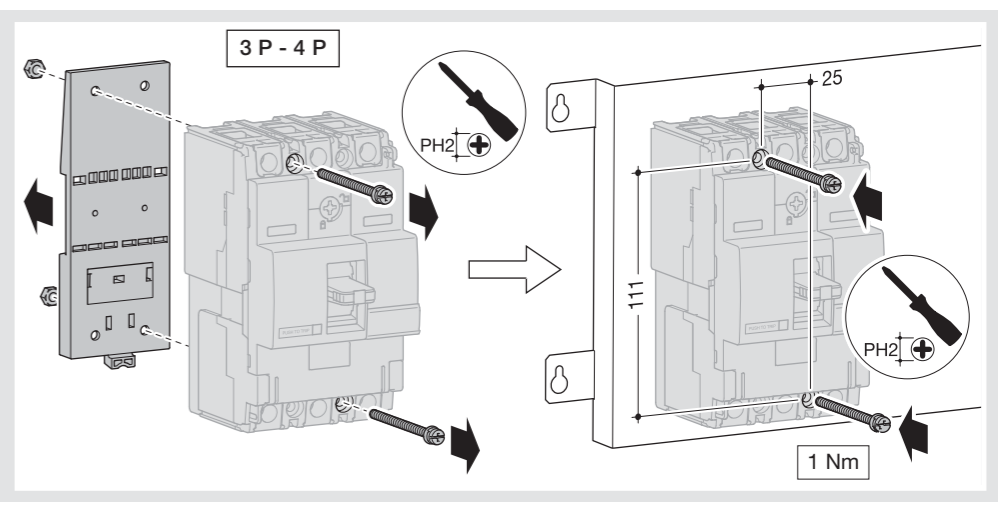
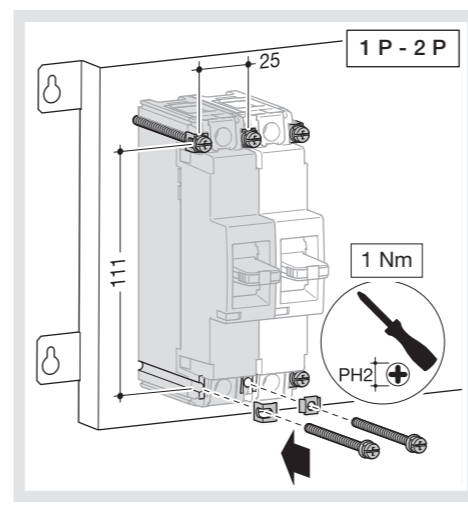

Hager.12.2012 OCOM 115104

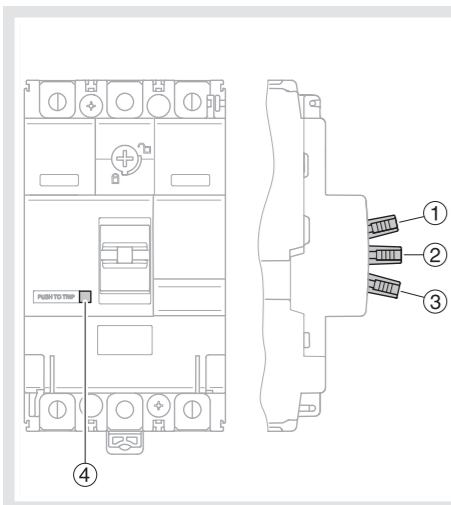

Indicateur de position de la manette :
 ① rouge = ON, ② blanc = Déclenché,
 ③ vert = OFF (Reset).
 Bouton de déclenchement ④

Handle position indicator :
 ① red = ON, ② white = Trip,
 ③ green = AUS (Reset).
 Button, Push-to-Trip ④

Position des Schaltebels :
 ① rot = EIN, ② weiss = ausgelöst,
 ③ grün = AUS (Reset).
 Prüftaste, zum Auslösen drücken ④

Indicatore di posizione della leva di manovra :
 ① rosso = ON, ② bianco = Scanciato,
 ③ verde = OFF (Reset).
 Pulsante di sgancio ④

Visualización de la posición :
 ① rojo = ON, ② blanco = Disparo,
 ③ verde = OFF (Reset).
 Pulsador de disparo ④

Hendelstand-indicator :
 ① rood = ON,
 ② wit = Uitgeschakeld,
 ③ groen = OFF (Reset).
 Uitschakelknop ④

Indicador de posição do punho :
 ① encarnado = ON,
 ② branco = Disparo,
 ③ verde = OFF (Reset).
 Botão de disparo ④

Bryterknappens posisjon indikerer :
 ① rødt = PÅ,
 ② hvitt = Utløst,
 ③ grønt = AV (Reset).
 Utløserknapp ④

Οπτική ένδειξη της κατάστασης του διακόπτη :
 ① κόκκινο = ON,
 ② λευκό = πτώση διακόπτη ισχύος,
 ③ πράσινο = OFF (Reset).
 Πλήκτρο διακοπής ④

Pozycje dźwigni:
 ① czerwony = WKL,
 ② biały = Trip
 ③ zielony = OFF (Reset)
 Przycisk - Wciśnij aby wyzwolić ④

Индикатор положения раб. органа:
 ① красный = ВКЛ,
 ② белый = расцеплен
 ③ зелёный = Выкл(Готов)
 Кнопка. Нажать для расцепления ④

مشير الوضعية وحدة التحكم
 ① احمر = تشغيل
 ② ابيض = انطلاق
 ③ اخضر = ايقاف
 ④ زر الانطلاق

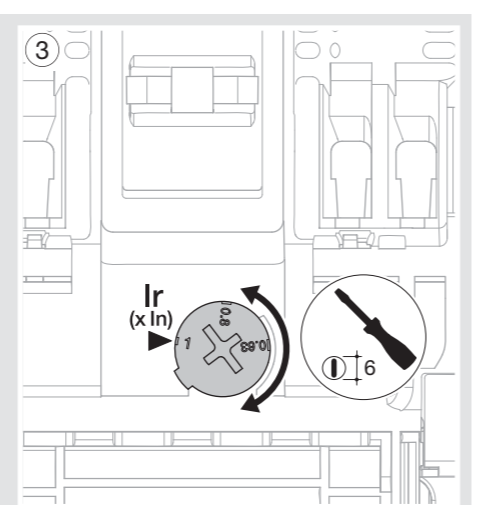
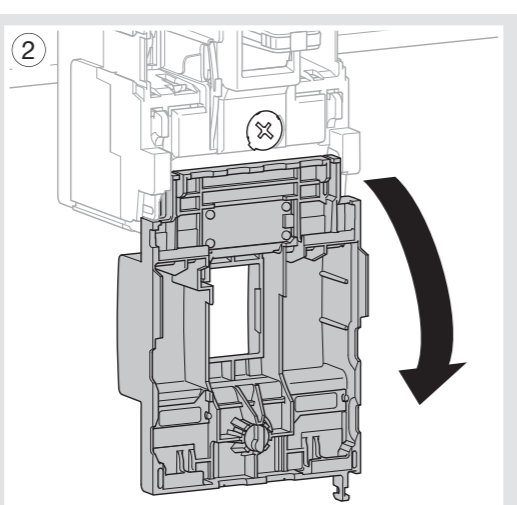
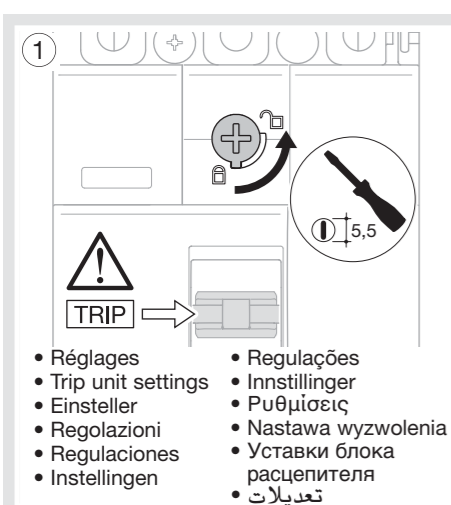
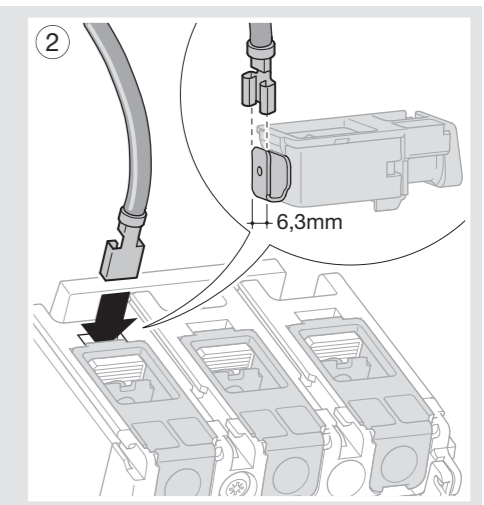
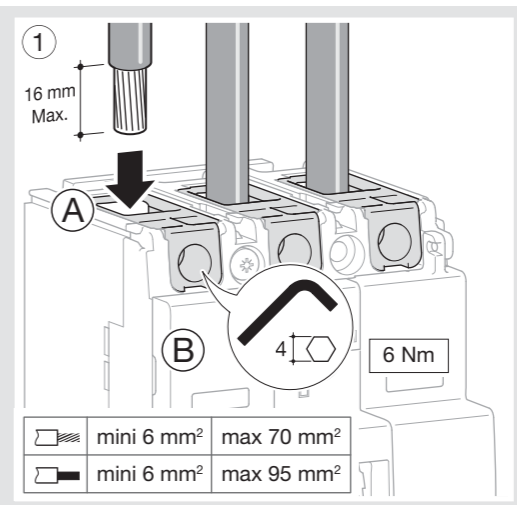
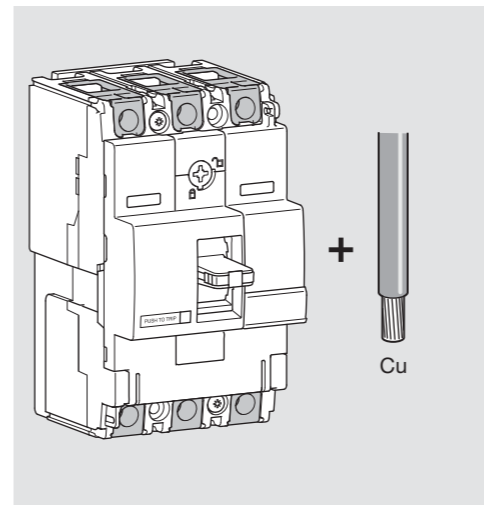

- Réglages
- Trip unit settings
- Einsteller
- Regolazioni
- Regulaciones
- Instellingen
- Regulações
- Innstillinger
- Ρυθμίσεις
- Nastawa wyzwoleń
- Уставки блока расцепителя
- تعديلات

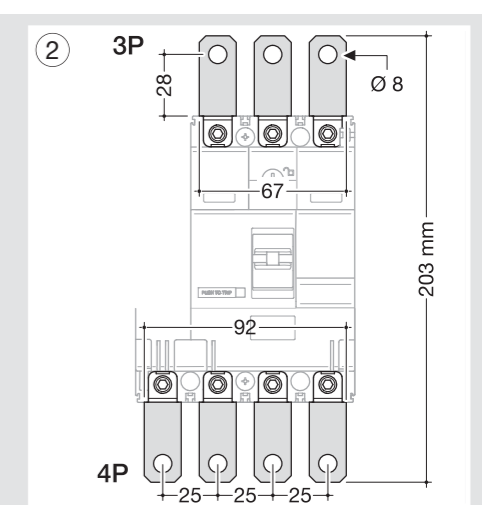
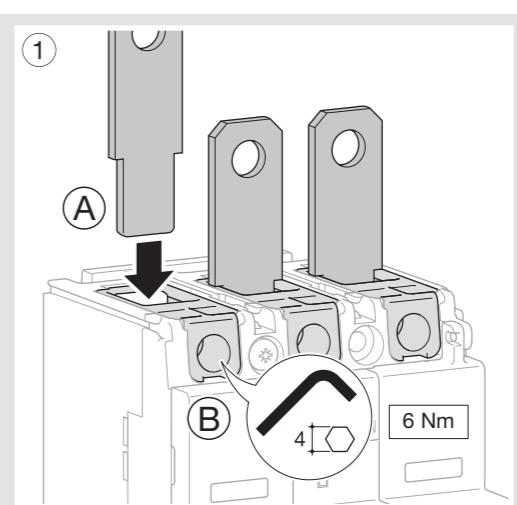
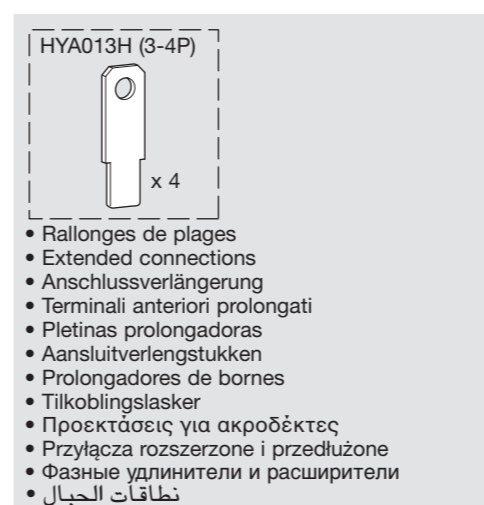

- Rallonges de plages
- Extended connections
- Anschlussverlängerung
- Terminali anteriori prolungati
- Pletinas prolongadoras
- Aansluitverlengstukken
- Prolongadores de bornes
- Tilkoblingslasker
- Προεκτάσεις για ακροδέκτες
- Przyłącza rozszerzone i przedłużone
- Фазные удлинители и расширители
- نطاقات الحبال

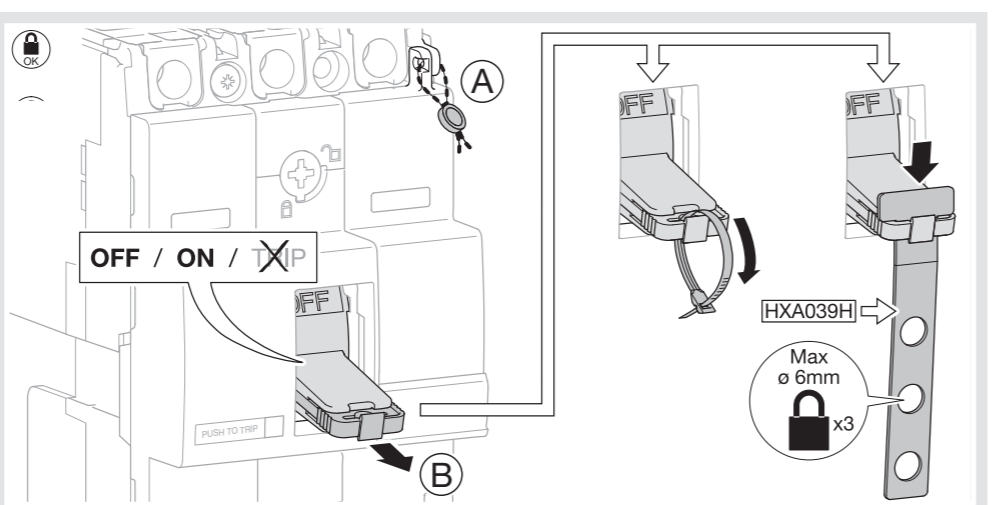
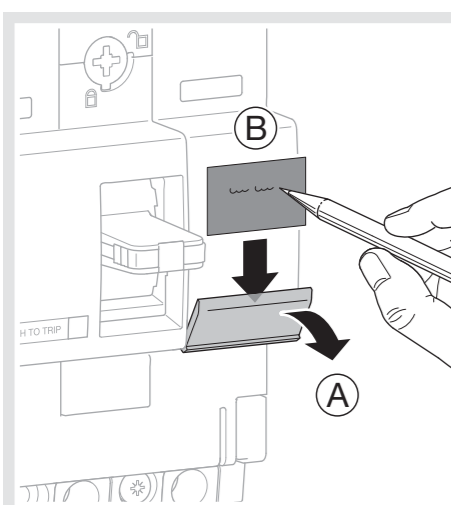

- OFF / ON / TRIP
- HXA039H
- Max ø 6mm
- x3

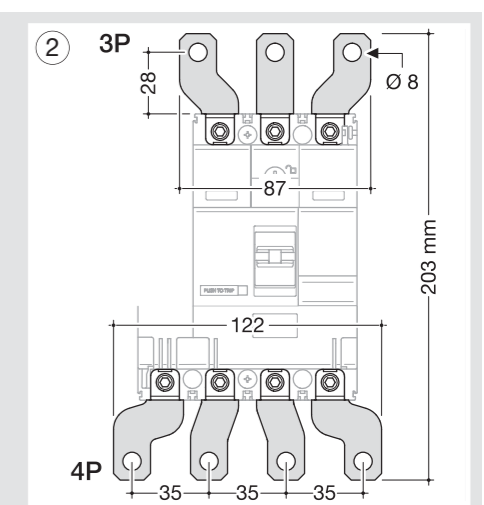
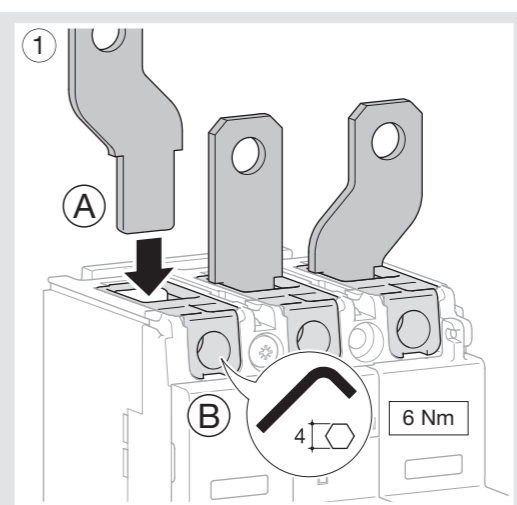
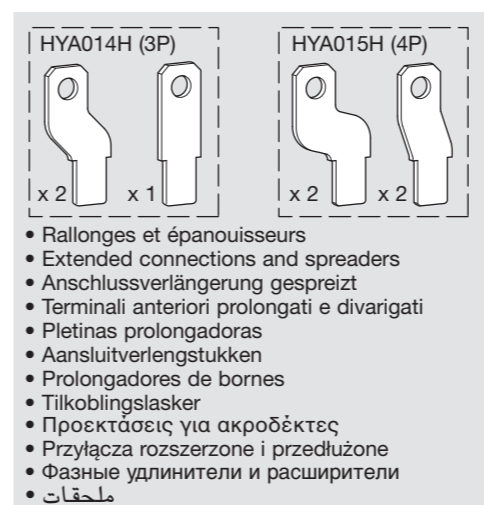

- Rallonges et épanouisseurs
- Extended connections and spreaders
- Anschlussverlängerung gespreizt
- Terminali anteriori prolungati e divarigati
- Pletinas prolongadoras
- Aansluitverlengstukken
- Prolongadores de bornes
- Tilkoblingslasker
- Προεκτάσεις για ακροδέκτες
- Przyłącza rozszerzone i przedłużone
- Фазные удлинители и расширители
- ملحقات

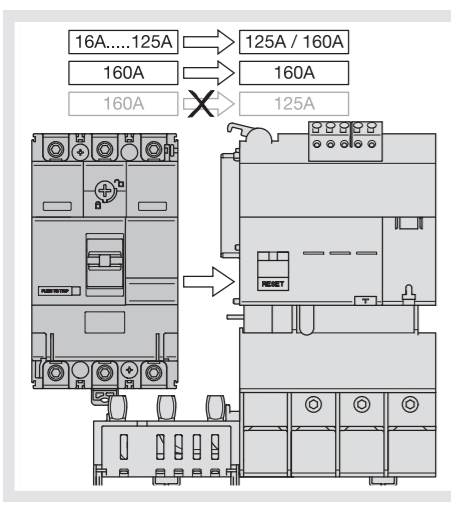

- L'association d'un disjoncteur 160 A avec un bloc différentiel 125 A est interdite.
- Assembly between MCCB 160 A and RCD 125 A is strictly forbidden.
- Montage zwischen MCCB 160 A und RCD 125 A ist strikt verboten.
- E' vietato installare un blocco differenziale da 125 A su un interruttore da 160 A.
- El acoplamiento entre un interruptor automático de 160 A y un bloque diferencial de 125 A está prohibido.
- Het is niet toegestaan een aardlekelement met een nom. waarde van 125 A te combineren met een vermogensschakelaar met een nom. waarde van 160 A.
- Não é permitida a associação de um disjuntor de 160 A com um bloco diferencial de 125 A.
- Montasje av 125 A jordfeilblokk på 160 A effektbryter må ikke forekomme.
- Απαγορεύεται η σύνδεση ενός διακόπτη 160 A με ένα ρελέ διαφυγής (μπλοκ) 125 A.
- Montaż wyłącznika 160 A z blokiem różnicowoprądowym 125 A jest niedopuszczalny.
- Сборка автомата 160A и блока ВДТ 125A строго воспрещается.
- "بناء القدرات" 160A مع فارق حظر 125A محظور تكوين الجمعيات

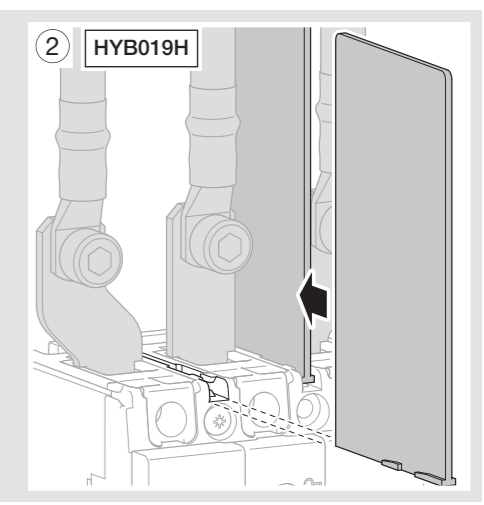
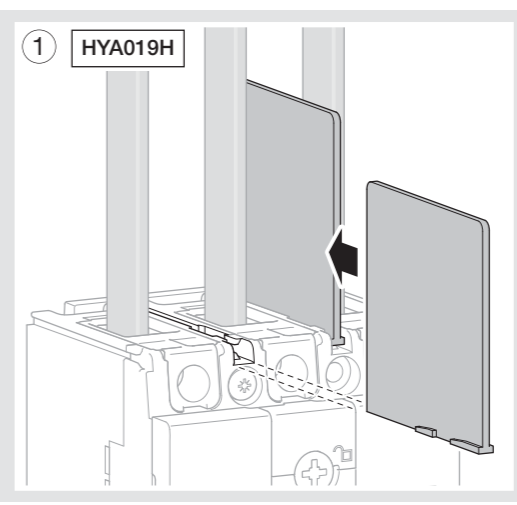
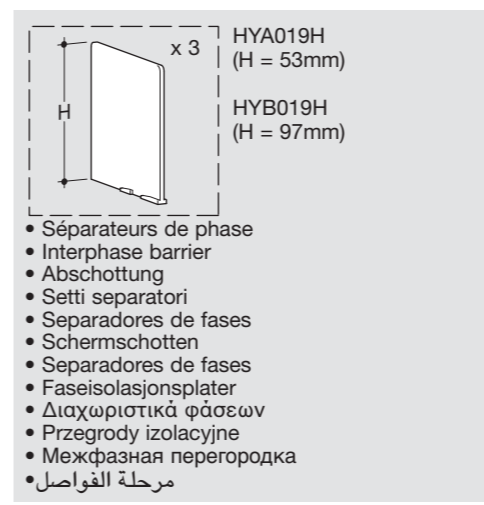

- Séparateurs de phase
- Interphase barrier
- Abschottung
- Setti separatori
- Separadores de fases
- Schermschotten
- Separadores de fases
- Faseisolasjonsplater
- Διαχωριστικά φάσεων
- Przegrody izolacyjne
- Межфазная перегородка
- مرحلة الفواصل